

1. General Description

This EPROM-Based 8-bit micro-controller uses a fully static CMOS technology process to achieve higher speed and smaller size with the low power consumption and high noise immunity. On chip memory includes 2K words of ROM, and 128 bytes of static RAM.

2. Features

The followings are some of the features on the hardware and software :

- ◆ Fully COMS static design
- ◆ 8-bit data bus
- ◆ On chip EPROM size : 2.0 K words
- ◆ Internal RAM size : 160 bytes
(128 general purpose registers, 32 special registers)
- ◆ 37 single word instructions
- ◆ 14-bit instructions
- ◆ 8-level stacks
- ◆ Operating voltage : 2.5 V ~ 6.0 V (PRD Disable)
4.5 V ~ 6.0 V (PRD Enable)
- ◆ Operating frequency : DC ~ 20 MHz
- ◆ The most fast execution time is 200 ns under 20 MHz in all single cycle instructions except the branch instruction
- ◆ Addressing modes include direct, indirect and relative addressing modes
- ◆ Power-on Reset
- ◆ Power edge-detector Reset
- ◆ Power range-detector Reset
- ◆ Sleep Mode for power saving
- ◆ Capture,Compare,PWM module
- ◆ Synchronous serial port with SCM
- ◆ 8 interrupt sources:
 - External INT pin
 - TMR0 timer,TMR1 timer,TMR2 timer
 - A/D conversion completion

-PortB<7:4> interrupt on change

-CCP,SCM

- ◆ A/D converter module:
 - 5 analog inputs multiplexed into one A/D converter
 - 8-bit resolution
- ◆ TMR0 : 8-bit real time clock/counter
TMR1 : 16-bit real time clock/count
TMR2 : 8-bit clock/counter(internal)
- ◆ 4 types of oscillator can be selected by programming option:
 - RC - Low cost RC oscillator
 - LFXT - Low frequency crystal oscillator
 - XTAL - Standard crystal oscillator
 - HFXT - High frequency crystal oscillator
- ◆ On-chip RC oscillator based Watchdog Timer(WDT)
- ◆ 22 I/O pins with their own independent direction control

3. Applications

The application areas of this MDT10P72 range from appliance motor control and high speed auto-motive to low power remote transmitters/receivers, pointing devices, and telecommunications processors, such as Remote controller, small instruments, chargers, toy, automobile and PC peripheral ... etc.

4. Pin Assignment

/MCLR	1	28	PB7
PA0/AIC0	2	27	PB6
PA1/AIC1	3	26	PB5
PA2/AIC2	4	25	PB4
PA3/AIC3/Vref	5	24	PB3
PA4/RTCC	6	23	PB2
PA5/SS/AIC4	7	22	PB1
V _{ss}	8	21	PB0/INT
OSC1/CLKIN	9	20	V _{dd}
OSC2/CLKOUT	10	19	V _{ss}
PC0/T1OSO/T1CKI	11	18	PC7
PC1/T1OSI	12	17	PC6
PC2/CCP	13	16	PC5/SDO
PC3/SCK	14	15	PC4/SDI

5. Pin Function Description

Pin Name	I/O	Function Description
PA0~PA3,PA5	I/O	Port A, TTL input level / Analog input channel
RTCC/PA4	I/O	Real Time Clock/Counter, Schmitt Trigger input level Open drain output
PB0~PB7	I/O	Port B, TTL input level / PB0:External interrupt input , PB4~PB7:Interrupt on pin change
PC0~PC7	I/O	Port C, Schmitt Trigger input level
/MCLR	I	Master Clear, Schmitt Trigger input level
OSC1/CLKIN	I	Oscillator Input/external clock input
OSC2/CLKOUT	O	Oscillator Output/in RC mode , the CLKOUT pin has 1/4 frequency of CLKIN
V _{dd}		Power supply
V _{ss}		Ground

6. Memory Map

(A) Register Map

Address	Description
BANK0	
00	Indirect Addressing Register
01	RTCC
02	PCL
03	STATUS
04	MSR
05	Port A
06	Port B
07	Port C
0A	PCH
0B	INTS
0C	PIFB1
0E	TMR1L
0F	TMR1H
10	T1STA
11	TMR2
12	T2STA
13	SCMBUF
14	SCMCTL
15	CCPL
16	CCPH
17	CCPCTL
1E	ADRES
1F	ADS0
20-7F	General purpose register
BANK1	
01	TMR
05	CPIO A
06	CPIO B

Address	Description
07	CPIO C
0C	PIEB1
0E	PSTA
12	T2PER
14	SCMSTA
1F	ADS1
A0~BF	General purpose register

- (1) IAR (Indirect Address Register) : R00
- (2) RTCC (Real Time Counter/Counter Register) : R01
- (3) PC (Program Counter) : R02,R0A

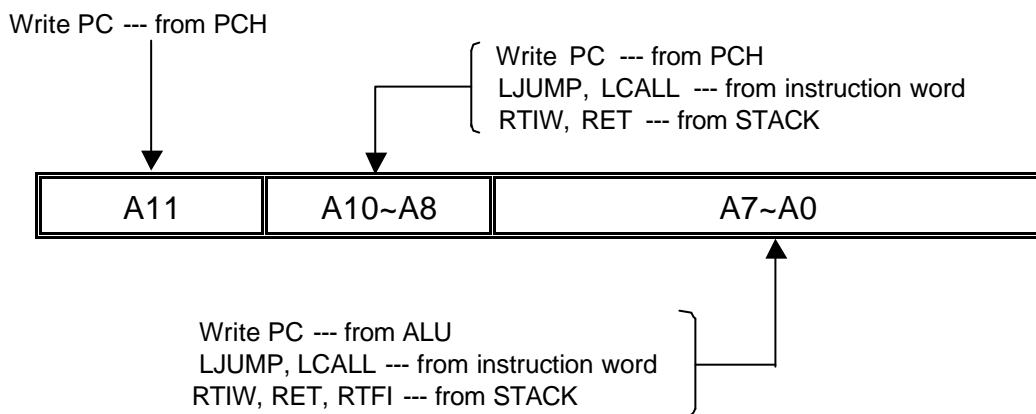

- (4) STATUS (Status register) : R03

Bit	Symbol	Function
0	C	Carry bit
1	HC	Half Carry bit
2	Z	Zero bit
3	PF	Power down Flag bit
4	TF	WDT Timer overflow Flag bit
5	RBS0	Register Bank Select bit : 0 : 00H --- 7FH (Bank0) 1 : 80H --- FFH (Bank1)
7-6	---	General purpose bit

(5) MSR (Memory Bank Select Register) : R04

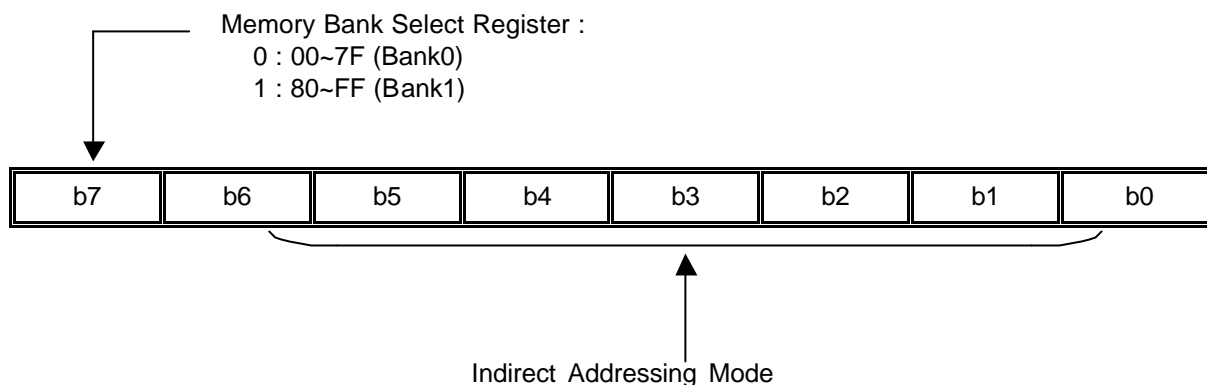

(6) PORT A : R05

PA5~PA0, I/O Register

(7) PORT B : R06

PB7~PB0, I/O Register

(8) PORT C : R07

PC7~PC0, I/O Register

(9)PCH (High byte of PC) : R0A

Bit	Function
4~0	High byte of PC
7~5	Unimplemented, reads as ' 0 '

(10) INTS (Interrupt Status Register) : R0B

Bit	Symbol	Function
0	RBIF	PORT B change interrupt flag. Set when PB <7:4> inputs change
1	INTF	Set when INT interrupt occurs. INT interrupt flag.
2	TIF	Set when TMR0 overflows.
3	RBIE	0 : disable PB change interrupt 1 : enable PB change interrupt
4	INTS	0 : disable INT interrupt 1 : enable INT interrupt
5	TIS	0 : disable TMR0 interrupt 1 : enable TMR0 interrupt
6	PEIE	0 : disable all peripheral interrupt 1 : enable all peripheral interrupt
7	GIS	0 : disable global interrupt 1 : enable global interrupt

(11) PIFB1 (Peripheral Interrupt Flag Bit) : R0C

Bit	Symbol	Function
0	TMR1IF	TMR1 interrupt flag 0 : TMR1 did not overflow 1 : TMR1 overflowed
1	TMR2IF	TMR2 interrupt flag 0 : No TMR2 to T2PER match occurred 1 : TMR2 to T2PER match occurred
2	CCPIF	CCP interrupt flag 0 : No TMR1 capture/compare occurred 1 : A TMR1 capture/compare occurred
3	SCMIF	SCM interrupt flag 0 : Waiting SCM transmit/receive 1 : The SCM transmission/reception is complete
5~4	--	Unimplemented
6	ADIF	A/D interrupt flag 0 : A/D conversion is not complete 1 : A/D conversion completed
7	--	Unimplemented

(12) TMR1L : R0E

The LSB of the 16-bit TMR1

(13) TMR1H : R0F

The MSB of the 16-bit TMR1

(14) T1STA : R10

Bit	Symbol	Function
0	TMR1ON	0 : Stop TMR1 1 : enable TMR1
1	TMR1CLK	0 : Internal clock (Fosc/4) 1 : External clock from pin PC0
2	/T1SYNC	TMR1CLK = 1 0 : Synchronize external clock 1 : Do not synchronize external clock TMR1CLK = 0 This bit is ignored
3	T1OSCEN	0 : TMR1 Oscillator is shut off 1 : TMR1 Oscillator is enable

Bit	Symbol	Function
5~4	T1CKPS1 ~ T1CKPS0	1 1 = 1:8 Prescale value 1 0 = 1:4 Prescale value 0 1 = 1:2 Prescale value 0 0 = 1:1 Prescale value
7~6	--	Unimplemented

(15) TMR2 : R11

TMR2 register

(16) T2STA : R12

Bit	Symbol	Function
1~0	T2CKPS1 ~ T2CKPS0	0 0 = Prescaler is 1 0 1 = Prescaler is 4 1 x = Prescaler is 16
2	TMR2ON	0 : TMR2 is on 1 : TMR2 is off
7~3	--	Unimplemented

(17) SCMBUF : R13

Serial communication port buffer

(18) SCMCTL : R14

Bit	Symbol	Function
3~0	SCM3 ~ SCM0	0 0 0 0 : SCM master mode , clock = Fosc/4 0 0 0 1 : SCM master mode , clock = Fosc/16 0 0 1 0 : SCM master mode , clock = Fosc/64 0 0 1 1 : SCM master mode , clock = TMR2 output/2 0 1 0 0 : SCM slave mode , clock = SCK pin , /SS control enable 0 1 0 1 : SCM slave mode , clock = SCK pin , /SS control disable
4	CKS	0 : Transmit happens on rising edge , receive on falling edge, Idle state for clock is low level 1 : Transmit happens on falling edge , receive on rising edge, Idle state for clock is high level.
5	SCMEN	0 : disable SCM, then pc3, pc4, pc5 is I/O port. 1 : enable SCM
6	SCMROI	0 : No overflow 1 : Overflow

Bit	Symbol	Function
7	WCOL	0 : No collision 1 : The SCMBUF is written while it is still transmitting the previous word

(19) CCPL : R15

Capture/Compare/PWM LSB

(20) CCPH : R16

Capture/Compare/PWM MSB

(21) CCPCTL : R17

Bit	Symbol	Function
3~0	CCPM3 ~ CCPM0	0 0 0 0 : CCP off 0 1 0 0 : Capture mode , every falling edge 0 1 0 1 : Capture mode , every rising edge 0 1 1 0 : Capture mode , every 4 th rising edge 0 1 1 1 : Capture mode , every 16 th rising edge 1 0 0 0 : Compare mode , set output on match 1 0 0 1 : Compare mode , clear output on match 1 0 1 0 : Compare mode , generate software interrupt on match 1 0 1 1 : Compare mode , trigger special event 1 1 x x : PWM mode
5~4	PWMLSB	These bits are the two LSBs of the PWM duty cycle
7~6	--	Unimplemented

(22) ADRES (A/D result register) : R1E

(23) ADS0 (A/D Status Register) : R1F

Bit	Symbol	Function
0	ADRUN	0 : A/D converter module is shut off and consumes no operating current 1 : A/D converter module is operating
1	--	Unimplemented
2	GO/DONEB	0 : A/D conversion in progress 1 : A/D conversion not in progress
5~3	CHS2~0	000 : AIC0 001 : AIC1 010 : AIC2 011 : AIC3 100 : AIC4
7~6	ASCS1-0	00 : fosc/2 01: fosc/8 10 : fosc/32 11 : f RC (*Note)

*Note: determined by OSC mode, HF: fosc/32 XT: fosc/8 RC: fosc/2 LF: fosc/2

(24) TMR (Time Mode Register) : R81

Bit	Symbol	Function		
2~0	PS2~0	Prescaler Value	RTCC rate	WDT rate
		0 0 0	1 : 2	1 : 1
		0 0 1	1 : 4	1 : 2
		0 1 0	1 : 8	1 : 4
		0 1 1	1 : 16	1 : 8
		1 0 0	1 : 32	1 : 16
		1 0 1	1 : 64	1 : 32
		1 1 0	1 : 128	1 : 64
1 1 1	1 : 256	1 : 128		
3	PSC	Prescaler assignment bit : 0 — RTCC 1 — Watchdog Timer		
4	TCE	RTCC signal Edge : 0 — Increment on low-to-high transition on RTCC pin 1 — Increment on high-to-low transition on RTCC pin		
5	TCS	RTCC signal set : 0 — Internal instruction cycle clock 1 — Transition on RTCC pin		
6	IES	Interrupt edge select 0 — Interrupt on falling edge on PB0 1 — Interrupt on rising edge on PB0		
7	PBPH	PORTB pull-hi 0 — PORTB pull-hi are enable 1 — PORTB pull-hi are disable		

(25) CPIO A (Control Port I/O Mode Register) : R85

= "0", I/O pin in output mode;
= "1", I/O pin in input mode.

(26) CPIO B (Control Port I/O Mode Register) : R86

= "0", I/O pin in output mode;
= "1", I/O pin in input mode.

(27) CPIO C (Control Port I/O Mode Register) : R87

= "0", I/O pin in output mode;
= "1", I/O pin in input mode.

(28) PIEB1 : R8C

Bit	Symbol	Function
0	TMR1IE	TMR1 interrupt enable bit 0 : disable TMR1 interrupt 1 : enable TMR1 interrupt
1	TMR2IE	TMR2 interrupt enable bit 0 : disable TMR2 interrupt 1 : enable TMR2 interrupt

Bit	Symbol	Function
2	CCPIE	CCP interrupt enable bit 0 : disable CCP interrupt 1 : enable CCP interrupt
3	SCMIE	SCM interrupt enable bit 0 : disable SCM interrupt 1 : enable SCM interrupt
5~4	--	Unimplemented
6	ADIE	A/D interrupt enable bit 0 : disable A/D interrupt 1 : enable A/D interrupt
7	--	Unimplemented

(29) PSTA : R8E

Bit	Symbol	Function
0	PRDB	0:Power range-detector Reset occurred 1:No Power range-detector Reset Occurred
1	PORB	0:Power on Reset occurred 1:No Power on Reset occurred

(30) T2PER : R92

Timer2 period

(31) SCMSTA : R94

Bit	Symbol	Function
0	BF	0 : Receive not complete 1 : Receive complete
7~1	--	Unimplemented

(32) ADS1 (A/D Status Register) : R9F

Bit	Symbol	Function
2~0	PAVM2~0	0 0 0 : PA0~3,PA5 = analog input . VREF = VDD 0 0 1 : PA0~2,PA5 = analog input . PA3 =ref input, VREF =PA3 0 1 0 : PA0~3,PA5 = analog input . VREF = VDD 0 1 1 : PA0~2,PA5 = analog input . PA3 =ref input, VREF =PA3 1 0 0 : PA0,1,3 = analog input . PA2,5 = digital I/O, VREF = VDD 1 0 1 : PA0,1 = analog input . PA2,5 = digital I/O, VREF =PA3 1 1 x : PA0~3,5 = digital I/O

(33) Configurable options for EPROM (Set by writer) :

Oscillator Type
RC Oscillator
HFXT Oscillator
XTAL Oscillator
LFXT Oscillator

Watchdog Timer control
Watchdog timer disable all the time
Watchdog timer enable all the time

Power-range control
Power-range disable
Power-range enable

Oscillator-start Timer control
0ms
80ms

Power-edge Detect
PED Disable
PED Enable

Security state
Security Disable
Security Enable

(B) Program Memory

Address	Description
000-7FF	Program memory
000	The starting address of power on, external reset or WDT time-out reset.
004	Interrupt vector

7. Reset Condition for all Registers

Register	Address	Power-On Reset, Power range detector Reset	/MCLR or WDT Reset	Wake-up from SLEEP
IAR	00h	N/A	N/A	N/A
RTCC	01h	xxxx xxxx	uuuu uuuu	uuuu uuuu
PC	0Ah,02h	0000 0000 0000	0000 0000 0000	PC+1
STATUS	03h	0001 1xxx	000# #uuu	000# #uuu
MSR	04h	xxxx xxxx	uuuu uuuu	uuuu uuuu
PORT A	05h	--xx xxxx	--uu uuuu	--uu uuuu
PORT B	06h	xxxx xxxx	uuuu uuuu	uuuu uuuu
PORT C	07h	xxxx xxxx	uuuu uuuu	uuuu uuuu
PCH	0Ah	---0 0000	---0 0000	---u uuuu
INTS	0Bh	0000 000x	0000 000u	uuuu uuuu
PIFB1	0Ch	-0-- 0000	-0-- 0000	-u-- uuuu
TMR1L	0Eh	xxxx xxxx	uuuu uuuu	uuuu uuuu
TMR1H	0Fh	xxxx xxxx	uuuu uuuu	uuuu uuuu
T1STA	10h	--00 0000	--uu uuuu	--uu uuuu
TMR2	11h	0000 0000	0000 0000	uuuu uuuu
T2STA	12h	---- -000	---- -uuu	---- -uuu
SCMBUF	13h	xxxx xxxx	uuuu uuuu	uuuu uuuu
SCMCTL	14h	0000 0000	0000 0000	uuuu uuuu
CCPL	15h	xxxx xxxx	uuuu uuuu	uuuu uuuu
CCPH	16h	xxxx xxxx	uuuu uuuu	uuuu uuuu
CCPCTL	17h	--00 0000	--00 0000	--uu uuuu
ADRES	1Eh	xxxx xxxx	uuuu uuuu	uuuu uuuu
ADS0	1Fh	0000 00-0	0000 00-0	uuuu uu-u
TMR	81h	1111 1111	1111 1111	uuuu uuuu
CPIOA	85h	--11 1111	--11 1111	--uu uuuu
CPIOB	86h	1111 1111	1111 1111	uuuu uuuu
CPIOC	87h	1111 1111	1111 1111	uuuu uuuu
PIEB1	8Ch	-0-- 0000	-0-- 0000	-u-- uuuu
PSTA	8Eh	---- --0u	---- --uu	---- --uu

This specification are subject to be changed without notice. Any latest information please preview

Register	Address	Power-On Reset, Power range detector Reset	/MCLR or WDT Reset	Wake-up from SLEEP
T2PER	92h	1111 1111	1111 1111	1111 1111
SCMSTA	94h	---- ---0	---- ---0	---- ---u
ADS1	9Fh	---- -000	---- -000	---- -uuu

Note : u = unchanged, x = unknown, - = unimplemented, read as "0"

= value depends on the condition of the following table

Condition	Status: bit 4	Status: bit 3	PSTA: bit 1	PSTA: bit 0
/MCLR reset (not during SLEEP)	u	u	u	u
/MCLR reset during SLEEP	1	0	u	u
WDT reset (not during SLEEP)	0	1	u	u
WDT reset during SLEEP	0	0	u	u
Power-on reset	1	1	0	x
Power-range reset	1	1	u	0

8. Instruction Set :

Instruction Code	Mnemonic Operands	Function	Operating	Status
010000 00000000	NOP	No operation	None	
010000 00000001	CLRWT	Clear Watchdog timer	0 WT	TF, PF
010000 00000010	SLEEP	Sleep mode	0 WT, stop OSC	TF, PF
010000 00000011	TMODE	Load W to TMODE register	W TMODE	None
010000 00000100	RET	Return from subroutine	Stack PC	None
010000 00000rrr	CPIO R	Control I/O port register	W CPIO r	None
010001 1rrrrrrr	STWR R	Store W to register	W R	None
011000 trrrrrrr	LDR R, t	Load register	R t	Z
111010 iiiiii	LDWI I	Load immediate to W	I W	None
010111 trrrrrrr	SWAPR R, t	Swap halves register	[R(0~3) ↔ R(4~7)] t	None
011001 trrrrrrr	INCR R, t	Increment register	R + 1 t	Z
011010 trrrrrrr	INCRSZ R, t	Increment register, skip if zero	R + 1 t	None
011011 trrrrrrr	ADDWR R, t	Add W and register	W + R t	C, HC, Z
011100 trrrrrrr	SUBWR R, t	Subtract W from register	R - W t or (R+/W+1 t)	C, HC, Z

This specification are subject to be changed without notice. Any latest information please preview

Instruction Code	Mnemonic Operands	Function	Operating	Status
011101 trrrrrr	DECR R, t	Decrement register	R - 1 t	Z
011110 trrrrrr	DECRSZ R, t	Decrement register, skip if zero	R - 1 t	None
010010 trrrrrr	ANDWR R, t	AND W and register	R W t	Z
110100 iiiiiii	ANDWI i	AND W and immediate	i W W	Z
010011 trrrrrr	IORWR R, t	Inclu. OR W and register	R W t	Z
110101 iiiiiii	IORWI i	Inclu. OR W and immediate	i W W	Z
010100 trrrrrr	XORWR R, t	Exclu. OR W and register	R W t	Z
110110 iiiiiii	XORWI i	Exclu. OR W and immediate	i W W	Z
011111 trrrrrr	COMR R, t	Complement register	/R t	Z
010110 trrrrrr	RRR R, t	Rotate right register	R(n) R(n-1), C R(7), R(0) C	C
010101 trrrrrr	RLR R, t	Rotate left register	R(n) r(n+1), C R(0), R(7) C	C
010000 1xxxxxxx	CLRW	Clear working register	0 W	Z
010001 0rrrrrr	CLRR R	Clear register	0 R	Z
0000bb brrrrrr	BCR R, b	Bit clear	0 R(b)	None
0010bb brrrrrr	BSR R, b	Bit set	1 R(b)	None
0001bb brrrrrr	BTSC R, b	Bit Test, skip if clear	Skip if R(b)=0	None
0011bb brrrrrr	BTSS R, b	Bit Test, skip if set	Skip if R(b)=1	None
100nnn nnnnnnn	LCALL n	Long CALL subroutine	n PC, PC+1 Stack	None
101nnn nnnnnnn	LJUMP n	Long JUMP to address	n PC	None
110111 iiiiiii	ADDWI i	Add immediate to W	W+i W	C,HC,Z
110001 iiiiiii	RTIW i	Return, place immediate to W	Stack PC,i W	None
111000 iiiiiii	SUBWI i	Subtract W from immediate	i-W W	C,HC,Z
010000 00001001	RTFI	Return from interrupt	Stack PC,1 GIS	None

Note :

W	: Working register	b	: Bit position
WT	: Watchdog timer	t	: Target
TMODE	: TMODE mode register	0	: Working register
CPIO	: Control I/O port register	1	: General register
TF	: Timer overflow flag	R	: General register address
PF	: Power loss flag	C	: Carry flag
PC	: Program Counter	HC	: Half carry
OSC	: Oscillator	Z	: Zero flag
Inclu.	: Inclusive ' '	/	: Complement
Exclu.	: Exclusive ' '	x	: Don't care
AND	: Logic AND ' '	i	: Immediate data (8 bits)
		n	: Immediate address

This specification are subject to be changed without notice. Any latest information please preview

9. Electrical Characteristics

*Note: Temperature=25°C

1. Absolute maximum rating

- Maximum current into Vdd pin : 250mA
- Maximum current out of Vss pin : 300mA
- Maximum current sourced by PortA : 150mA
- Maximum current sourced by PortB : 200mA
- Maximum current sourced by PortC : 200mA
- Maximum current sunk by PortA : 150mA
- Maximum current sunk by PortB : 200mA
- Maximum current sunk by PortC : 200mA
- Maximum output current sourced by any I/O pin : 25mA
- Maximum output current sunk by any I/O pin : 25mA

These parameters are for reference only.

2. Operation Current :

(1) HF (C=10p) , WDT - enable, PRD – disable

	4M	10M	20M	Sleep	Sleep , WDT-disable , PRD-disable
2.5V	350u	770u	1.4m	20u	1u
3.0V	450u	880u	1.7m	37u	1u
4.0V	730u	1.4m	2.6m	42u	1u
5.0V	1.1m	2.0m	3.6m	52u	1u
6.0V	1.6m	2.9m	4.8m	80u	1u

These parameters are for reference only.

(2) XT (C=10p) , WDT - enable, PRD – disable

	1M	4M	10M	Sleep	Sleep , WDT-disable , PRD-disable
2.5V	80u	220u	500u	12u	1u
3.0V	170u	400u	850u	37u	1u
4.0V	300u	700u	1.3m	42u	1u
5.0V	500u	1.0m	1.8m	52u	1u
6.0V	800u	1.4m	2.7m	80u	1u

These parameters are for reference only.

(3) LF (C=10p) , WDT - enable, PRD - disable,

	32K	455K	1M	Sleep	Sleep , WDT-disable , PRD-disable
2.5V	25u	(2.7V) 80u	100u	120u	1u
3.0V	35u	100u	130u	37u	1u
4.0V	50u	140u	190u	42u	1u
5.0V	100u	200u	250u	52u	1u
6.0V	200u	300u	350u	80u	1u

These parameters are for reference only.

(4) RC, WDT - enable; PRD - disable; @Vdd = 5.0V

C	R	Freq.	Current	Sleep , WDT-disable , PRD-disable
3p	4.7k	12.1M	1.9m	1u
	10k	6.3M	1.1m	1u
	47k	1.4M	350u	1u
	100k	702K	220u	1u
	300k	235K	140u	1u
	470k	149K	130u	1u
20p	4.7k	5.8M	1.0m	1u
	10k	2.9M	600u	1u
	47k	640K	210u	1u
	100k	310K	160u	1u
	300k	104K	130u	1u
	470k	66K	120u	1u
100p	4.7k	1.7M	380u	1u
	10k	865K	250u	1u
	47k	190K	140u	1u
	100k	91K	130u	1u
	300k	31K	110u	1u
	470k	19K	105u	1u
300p	4.7k	740K	220u	1u
	10k	362K	170u	1u
	47k	79K	140u	1u
	100k	38K	110u	1u
	300k	13K	105u	1u
	470k	8K	105u	1u

This specification are subject to be changed without notice. Any latest information please preview

These parameters are for reference only.

RC, WDT - enable; PRD - disable; @Vdd = 3.0V

C	R	Freq.	Current	Sleep , WDT-disable , PRD-disable
3p	4.7k	11.8M	1.1m	1u
	10k	6.7M	580u	1u
	47k	1.7M	190u	1u
	100k	900K	150u	1u
	300k	275K	80u	1u
	470k	176K	70u	1u
20p	4.7k	6.4M	600u	1u
	10k	3.4M	330u	1u
	47k	790K	120u	1u
	100k	380K	90u	1u
	300k	127K	70u	1u
	470k	81K	60u	1u
100p	4.7k	2.2M	230u	1u
	10k	1.1M	150u	1u
	47k	250K	80u	1u
	100k	120K	70u	1u
	300k	40K	60u	1u
	470k	26K	60u	1u
300p	4.7k	1.0M	150u	1u
	10k	520K	110u	1u
	47k	115K	70u	1u
	100k	55K	65u	1u
	300k	18K	60u	1u
	470k	12K	60u	1u

These parameters are for reference only.

3. Input Voltage (Vdd = 5V) :

	Port	Min	Max
Vil	TTL	Vss	1.0V
	Schmitt trigger	Vss	0.6V
Vih	TTL	2.2V	Vdd
	Schmitt trigger	3.8V	Vdd

This specification are subject to be changed without notice. Any latest information please preview

These parameters are for reference only.

Input Voltage (Vdd = 3V) :

	Port	Min	Max
Vil	TTL	Vss	0.8V
	Schmitt trigger	Vss	0.4V
Vih	TTL	2.0V	Vdd
	Schmitt trigger	2.6V	Vdd

These parameters are for reference only.

4. Output Voltage (Vdd = 5V) :

	PA,PB	Condition
Voh	4.4V	Ioh = -20mA
Vol	1.2V	Iol = 20mA
Voh	4.6V	Ioh = -5mA
Vol	0.5V	Iol = 5mA

These parameters are for reference only.

Output Voltage (Vdd = 3V) :

	PA,PB	Condition
Voh	1.2V	Ioh = -20mA
Vol	0.6V	Iol = 20mA
Voh	2.4V	Ioh = -5mA
Vol	0.4V	Iol = 5mA

These parameters are for reference only.

5. The basic WDT time-out cycle time :

	Time
2.5V	25
3.0V	23
4.0V	20
5.0V	17
6.3V	16

Unit = ms

These parameters are for reference only.

6. Temperature & WDT (Vdd = 5V) :

Temperature(°C)	-40	-20	0	30	50	80
WDT time(ms)	12.5	14.2	16.1	17.5	19.5	21.7

These parameters are for reference only.

7. PRD :

(1)PRD reset voltage :

	Voltage
Vih	4.0±10%
Vil	3.6±10%

Unit = V

These parameters are for reference only.

(2) PRD reset current :

	Current
4.0V	100
3.6V	80

Unit = uA

These parameters are for reference only.

8. Pull high resistor :

Vdd	5V	3V
Pull high	45	85

Unit = K Ohm

These parameters are for reference only.

9. MCLR filter time :

Vdd=5V	
time	720

Unit = ns

These parameters are for reference only.

10.OSC1 timing requirements :

External clock high or low time (osc1)	2.5us (min) LF mode (1MHz)
	80ns (min) XT mode (4MHz)
	15ns (min) HF mode (20MHz)
External clock rise or fall time (osc1)	50ns (max) LF mode (1MHz)
	15ns (max) XT mode (4MHz)
	5ns (max) HF mode (20MHz)

These parameters are for reference only.

11.OSC1 and CLKOUT requirements :

OSC1 high to CLKOUT high	80ns (typical) RC mode
OSC1 high to CLKOUT low	80ns (typical) RC mode
CLKOUT rise time	50ns (typical) RC mode
CLKOUT fall time	50ns (typical) RC mode

These parameters are for reference only.

12.OSC1 and PORT OUTPUT requirements :

OSC1 high to PORT OUTPUT valid	100ns (typical)
PORT OUTPUT rise time	40ns (typical)
PORT OUTPUT fall time	40ns (typical)

These parameters are for reference only.