

1. General Description

This ROM-Based 8-bit micro-controller uses a fully static CMOS technology process to achieve higher speed and smaller size with the low power consumption and high noise immunity. On chip memory includes 1K words of ROM, and 36 bytes of static RAM.

2. Features

The followings are some of the features on the hardware and software :

- ◆ Fully COMS static design
- ◆ 8-bit data bus
- ◆ On chip ROM size : 1.0 K words
- ◆ Internal RAM size : 49 bytes
(36 general purpose registers, 13 special registers)
- ◆ 37 single word instructions
- ◆ 14-bit instructions
- ◆ 8-level stacks
- ◆ Operating voltage : 2.5 V ~ 6.5 V (PRD Disable)
- ◆ 4.5 V ~ 6.5 V (PRD Enable)
- ◆ Operating frequency : DC ~ 20 MHz
- ◆ The most fast execution time is 200 ns under 20 MHz in all single cycle instructions except the branch instruction
- ◆ Addressing modes include direct, indirect and relative addressing modes
- ◆ Power-on Reset
- ◆ Power edge-detector Reset
- ◆ Power range-detector Reset
- ◆ Sleep Mode for power saving
- ◆ 3 interrupt sources:
 - External INT pin
 - TMR0 timer
 - PortB<7:4> interrupt on change

- ◆ 4 types of oscillator can be selected by programming option:
 - RC - Low cost RC oscillator
 - LFXT - Low frequency crystal oscillator
 - XTAL - Standard crystal oscillator
 - HFXT - High frequency crystal oscillator
- ◆ 8-bit real time clock/counter(RTCC) with 8-bit programmable prescaler
- ◆ On-chip RC oscillator based Watchdog Timer(WDT)
- ◆ 13 I/O pins with their own independent direction control

3. Applications

The application areas of this MD1060 range from appliance motor control and high speed automotive to low power remote transmitters/receivers, pointing devices, and telecommunications processors, such as Remote controller, small instruments, chargers, toy, automobile and PC peripheral ..etc.

4. Pin Assignment

PA2	1	18	PA1
PA3	2	17	PA0
PA4/RTCC	3	16	OSC1
/MCLR	4	15	OSC2
V _{ss}	5	14	V _{dd}
PB0/INT	6	13	PB7
PB1	7	12	PB6
PB2	8	11	PB5
PB3	9	10	PB4

5. Pin Function Description

Pin Name	I/O	Function Description
PA0~PA3	I/O	Port A, TTL input level
PB0~PB7	I/O	Port B, TTL input level / PB0:External interrupt input , PB4~PB7:Interrupt on pin change
RTCC/PA4	I/O	Real Time Clock/Counter, Schmitt Trigger input levels Open drain output
/MCLR	I	Master Clear, Schmitt Trigger input levels
OSC1	I	Oscillator Input
OSC2	O	Oscillator Output
V _{dd}		Power supply
V _{ss}		Ground

6. Memory Map

(A) Register Map

Address	Description
BANK0	
00	Indirect Addressing Register
01	RTCC
02	PCL
03	STATUS
04	MSR
05	Port A
06	Port B
0A	PCH
0B	INTS
0C~2F	General purpose register
BANK1	
01	TMR
05	CPIO A
06	CPIO B
07	PSTA

- (1) IAR (Indirect Address Register) : R00
- (2) RTCC (Real Time Counter/Counter Register) : R01
- (3) PC (Program Counter) : R02,R0A

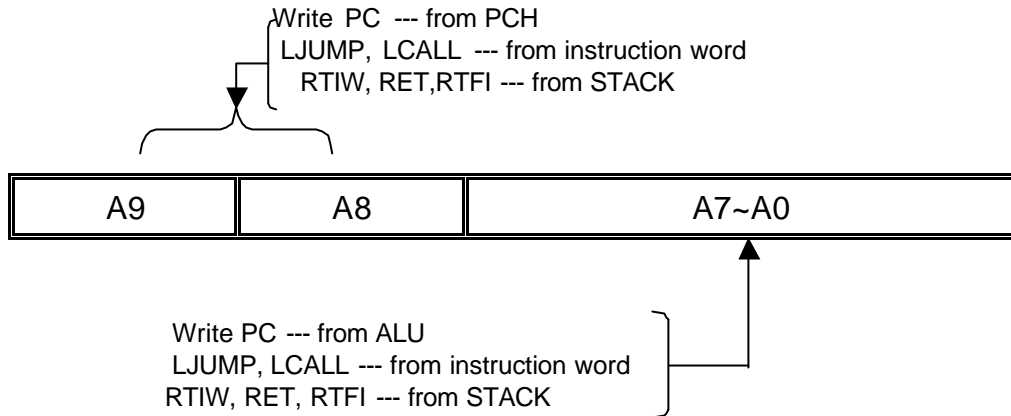

- (4) STATUS (Status register) : R03

Bit	Symbol	Function
0	C	Carry bit
1	HC	Half Carry bit
2	Z	Zero bit
3	PF	Power down Flag bit
4	TF	WDT Timer overflow Flag bit
5	RBS0	Register Bank Select bit : 0 : 00H --- 7FH 1 : 80H --- FFH
7~6	—	General purpose bit

- (5) MSR (Memory Bank Select Register) : R4

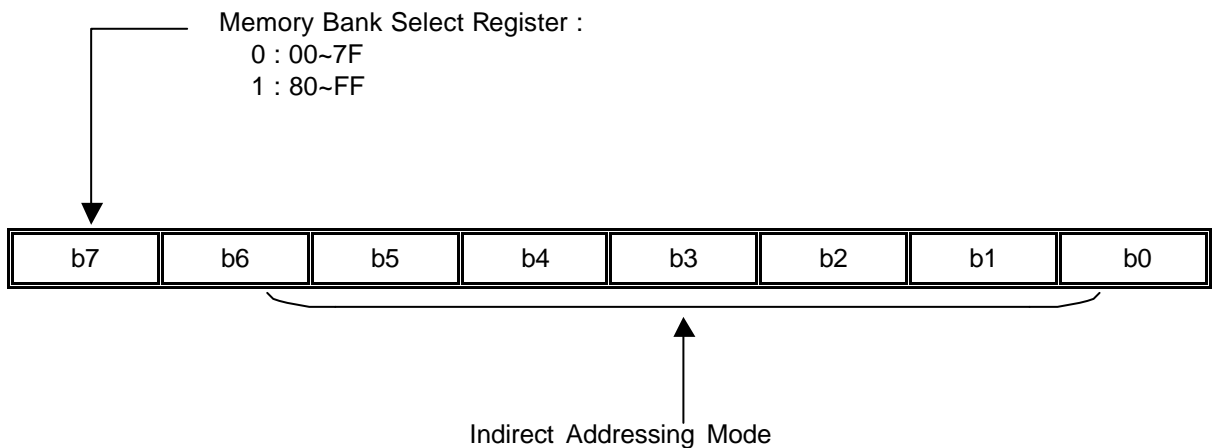

(6) PORT A : R05

PA4~PA0, I/O Register

(7) PORT B : R06

PB7~PB0, I/O Register

(8)PCH (High byte of PC) : R0A

Bit	Function
1~0	High byte of PC
7~2	Unimplemented, reads as ' 0 '

(9) INTS (Interrupt Status Register) : R0B

Bit	Symbol	Function
0	RBIF	PORT B change interrupt flag. Set when PB <7:4> inputs change
1	INTF	Set when INT interrupt occurs. INT interrupt flag.
2	TIF	Set when TMR overflows.
3	RBIE	0 : disable PB change interrupt 1 : enable PB change interrupt
4	INTS	0 : disable INT interrupt 1 : enable INT interrupt
5	TIS	0 : disable TMR interrupt 1 : enable TMR interrupt
6	--	Unimplemented
7	GIS	0 : disable global interrupt 1 : enable global interrupt

(10) TMR (Time Mode Register) : R81

Bit	Symbol	Function		
		Prescaler Value	RTCC rate	WDT rate
2—0	PS2—0	0 0 0	1 : 2	1 : 1
		0 0 1	1 : 4	1 : 2
		0 1 0	1 : 8	1 : 4
		0 1 1	1 : 16	1 : 8
		1 0 0	1 : 32	1 : 16
		1 0 1	1 : 64	1 : 32
		1 1 0	1 : 128	1 : 64
		1 1 1	1 : 256	1 : 128

Bit	Symbol	Function
3	PSC	Prescaler assignment bit : 0 — RTCC 1 — Watchdog Timer
4	TCE	RTCC signal Edge : 0 — Increment on low-to-high transition on RTCC pin 1 — Increment on high-to-low transition on RTCC pin
5	TCS	RTCC signal set : 0 — Internal instruction cycle clock 1 — Transition on RTCC pin
6	IES	Interrupt edge select 0 — Interrupt on falling edge on PB0 1 — Interrupt on rising edge on PB0
7	PBPH	PORTB pull-hi 0 — PORTB pull-hi are enable 1 — PORTB pull-hi are disable

(11) CPIO A (Control Port I/O Mode Register) : R85
 = "0", I/O pin in output mode;
 = "1", I/O pin in input mode.

(12) CPIO B (Control Port I/O Mode Register) : R86
 = "0", I/O pin in output mode;
 = "1", I/O pin in input mode.

(13) PSTA : R87

Bit	Symbol	Function
0	PRDB	0:Power range-detector Reset occurred 1:No Power range-detector Reset Occurred
1	PORB	0:Power on Reset occurred 1:No Power on Reset occurred

(14) Configurable options for ROM :

Oscillator Type
RC Oscillator
HFXT Oscillator
XTAL Oscillator
LFXT Oscillator

Watchdog Timer control
Watchdog timer disable all the time
Watchdog timer enable all the time

Power-range control
Power-range disable
Power-range enable

Oscillator-start Timer control
0ms
80ms

Power-edge Detect
PED Disable
PED Enable

(B) Program Memory

Address	Description
000-3FF	Program memory
000	The starting address of power on, external reset or WDT time-out reset.
004	Interrupt vector

7. Reset Condition for all Registers

Register	Address	Power-On Reset, Power range detector Reset	/MCLR or WDT Reset	Wake-up from SLEEP
IAR	00h	-	-	-
RTCC	01h	xxxx xxxx	uuuu uuuu	uuuu uuuu
PC	0Ah,02h	00 0000 0000	00 0000 0000	00 0000 0100
STATUS	03h	0001 1xxx	000# #uuu	000# #uuu
MSR	04h	xxxx xxxx	uuuu uuuu	uuuu uuuu
PORT A	05h	-- -1 xxxx	-- -1 uuuu	-- -u uuuu
PORT B	06h	xxxx xxxx	uuuu uuuu	uuuu uuuu
INTS	0Bh	0000 0001	0000 000u	uuuu uuuu
TMR	81h	1111 1111	1111 1111	uuuu uuuu
CPIOA	85h	-- -1 1111	-- -1 1111	-- -u uuuu
CPIOB	86h	1111 1111	1111 1111	uuuu uuuu
PSTA	87h	---- --qq	---- --uu	---- --uu

Note : u = unchanged, x = unknown, - = unimplemented, read as "0"

= value depends on the condition of the following table

Condition	Status: bit 4	Status: bit 3	Status: bit 1	Status: bit 0
/MCLR reset (not during SLEEP)	u	u	1	1
/MCLR reset during SLEEP	1	0	1	1
WDT reset (not during SLEEP)	0	1	1	1
WDT reset during SLEEP	0	0	1	1
Power on reset	1	1	0	X
Power range-detector Reset	1	1	1	0

8. Instruction Set :

Instruction Code	Mnemonic Operands	Function	Operating	Status
010000 00000000	NOP	No operation	None	
010000 00000001	CLRWT	Clear Watchdog timer	0 WT	TF, PF
010000 00000010	SLEEP	Sleep mode	0 WT, stop OSC	TF, PF
010000 00000011	TMODE	Load W to TMODE register	W TMODE	None
010000 00000100	RET	Return from subroutine	Stack PC	None
010000 00000rrr	CPIO R	Control I/O port register	W CPIO r	None
010001 1rrrrrrr	STWR R	Store W to register	W R	None
011000 trrrrrrr	LDR R, t	Load register	R t	Z
111010 iiiiiii	LDWI I	Load immediate to W	I W	None
010111 trrrrrrr	SWAPR R, t	Swap halves register	[R(0-3) ↔ R(4-7)] t	None
011001 trrrrrrr	INCR R, t	Increment register	R + 1 t	Z
011010 trrrrrrr	INCRSZ R, t	Increment register, skip if zero	R + 1 t	None
011011 trrrrrrr	ADDWR R, t	Add W and register	W + R t	C, HC, Z
011100 trrrrrrr	SUBWR R, t	Subtract W from register	R - W t or (R+/W+1 t)	C, HC, Z
011101 trrrrrrr	DECR R, t	Decrement register	R - 1 t	Z
011110 trrrrrrr	DECRSZ R, t	Decrement register, skip if zero	R - 1 t	None
010010 trrrrrrr	ANDWR R, t	AND W and register	R W t	Z
110100 iiiiiii	ANDWI i	AND W and immediate	i W W	Z
010011 trrrrrrr	IORWR R, t	Inclu. OR W and register	R W t	Z
110101 iiiiiii	IORWI i	Inclu. OR W and immediate	i W W	Z
010100 trrrrrrr	XORWR R, t	Exclu. OR W and register	R W t	Z

Instruction Code	Mnemonic Operands	Function	Operating	Status
110110 iiiiii	XORWI i	Exclu. OR W and immediate	i W W	Z
011111 trrrrrr	COMR R, t	Complement register	/R t	Z
010110 trrrrrr	RRR R, t	Rotate right register	R(n) R(n-1), C R(7), R(0) C	C
010101 trrrrrr	RLR R, t	Rotate left register	R(n) r(n+1), C R(0), R(7) C	C
010000 1xxxxxxx	CLRW	Clear working register	0 W	Z
010001 0rrrrrr	CLRR R	Clear register	0 R	Z
0000bb brrrrrr	BCR R, b	Bit clear	0 R(b)	None
0010bb brrrrrr	BSR R, b	Bit set	1 R(b)	None
0001bb brrrrrr	BTSC R, b	Bit Test, skip if clear	Skip if R(b)=0	None
0011bb brrrrrr	BTSS R, b	Bit Test, skip if set	Skip if R(b)=1	None
100nnn nnnnnnnn	LCALL n	Long CALL subroutine	n PC, PC+1 Stack	None
101nnn nnnnnnnn	LJUMP n	Long JUMP to address	n PC	None
110111 iiiiii	ADDWI i	Add immediate to W	W+i W	C,HC,Z
110001 iiiiii	RTIW i	Return, place immediate to W	Stack PC,i W	None
111000 iiiiii	SUBWI i	Subtract W from immediate	i-W W	C,HC,Z
010000 00001001	RTFI	Return from interrupt	Stack PC,1 GIS	None

Note :

- | | | | |
|--------|-----------------------------|----|-----------------------------|
| W | : Working register | b | : Bit position |
| WT | : Watchdog timer | t | : Target |
| TMODE | : TMODE mode register | 0 | : Working register |
| CPIO | : Control I/O port register | 1 | : General register |
| TF | : Timer overflow flag | R | : General register address |
| PF | : Power loss flag | C | : Carry flag |
| PC | : Program Counter | HC | : Half carry |
| OSC | : Oscillator | Z | : Zero flag |
| Inclu. | : Inclusive ' ' | / | : Complement |
| Exclu. | : Exclusive ' ' | x | : Don't care |
| AND | : Logic AND ' ' | i | : Immediate data (8 bits) |
| | | n | : Immediate address |

9. Electrical Characteristics

*Note: Temperature=25°C

1. Operation Current :

(1) HF (C=10p) , WDT - enable, PRD – disable

	4M	10M	20M	Sleep
2.5V	300u	670u	1.4m	1u
3.0V	410u	880u	1.8m	2.5u
4.0V	650u	1.4m	2.6m	6.4u
5.0V	1m	1.9m	3.4m	12u
6.4V	1.5m	2.8m	4.9m	26u

(2) XT (C=10p) , WDT - enable, PRD – disable

	1M	4M	10M	Sleep
2.5V	100u	300u	700u	1u
3.0V	135u	380u	850u	2.5u
4.0V	240u	600u	1.35m	6.4u
5.0V	400u	900u	1.8m	12u
6.4V	720u	1.4m	2.6m	26u

(3) RC, WDT - Enable; PRD - Disable; @Vdd = 5.0V

C	R	Freq.	Current
3p	4.7k	10.2M	1.8m
	10k	5.64M	1.1m
	47k	1.35M	300u
	100k	654K	180u
	300k	223K	100u
	470k	144K	80u
20p	4.7k	4.78M	900u
	10k	2.47M	500u
	47k	560K	150u
	100k	268K	100u
	300k	90K	70u
	470k	58K	60u

C	R	Freq.	Current
100p	4.7k	1.43M	320u
	10k	721K	200u
	47k	158K	90u
	100k	75.4K	70u
	300k	25.2K	60u
	470k	16.2K	55u
300p	4.7k	641K	180u
	10k	320K	120u
	47k	70K	70u
	100k	33.3K	60u
	300k	11.1K	50u
	470k	7.1K	48u

(4) LF (C=10p) , WDT - enable, PRD - disable,

	32K	455K	1M	Sleep
2.5V	5u	40u	80u	1u
3.0V	8u	55u	100u	2.5u
4.0V	19u	85u	150u	6.4u
5.0V	45u	130u	200u	12u
6.4V	190u	195u	300u	26u

2. Input Voltage (Vdd = 5V) :

	Port	Min	Max
Vil	TTL	Vss	1.0V
	Schmitt trigger	Vss	1.0V
Vih	TTL	2.2V	Vdd
	Schmitt trigger	3.5V	Vdd

3. Output Voltage (Vdd = 5V) :

	PA,PB	Condition
Voh	3.7V	Ioh = -20mA
Vol	0.5V	Iol = 20mA
Voh	4.6V	Ioh = -5mA
Vol	0.3V	Iol = 5mA

4. Output Current (Max.) (Vdd = 5V) :

Port A:

	Current
source current	30mA
sink current	50mA

Port B:

	Current
source current	30mA
sink current	50mA

5. The basic WDT time-out cycle time :

	time
2.5V	25
3.0V	22
4.0V	19
5.0V	17
6.3V	15

Unit = ms

6. PRD :

(1)PRD reset voltage :

	Voltage
Vh	4.2±5%
VI	3.8±5%

Unit = V

(2) PRD reset current :

	Current
4.2V	100
3.8V	80

Unit = uA

7. Min Operation Voltage :

C =>	10p	20p	30p
XT, 20M	2.5	2.5	2.5
HF, 20M	2.5	2.5	2.5

Unit = V

RC, 1k, no cap.	2.5
-----------------	-----

Unit = V

C =>	0p	10p	20p
LF, 1M	2.6	2.9	3.1

Unit = V

8. Pull high/low resistor :

Vdd	5V	3V
Pull high	35	65
Pull low	35	65

Unit = kOhm

9. MCLR filter time :

Vdd=5V

time	600
------	-----

Unit = ns