

# MDT1010

## 1. General Description

This ROM-Based 8-bit micro-controller uses a fully static CMOS design technology combines higher speed and smaller size with the low power and high noise immunity of CMOS. On chip memory system includes 1.0 K bytes of ROM, and 32 bytes of static RAM.

## 2. Features

The followings are some of the features on the hardware and software :

- ◆ Fully COMS static design
- ◆ 8-bit data bus
- ◆ On chip ROM size : 1,024 words
- ◆ Internal RAM size : 32 bytes  
(25 general purpose registers, 7 special registers)
- ◆ 36 single word instructions
- ◆ 14-bit instructions
- ◆ 2-level stacks
- ◆ Operating voltage : 2.3V ~ 6.3 V
- ◆ Operating frequency : 0 ~ 20 MHz
- ◆ The most fast execution time is 200 ns under 20 MHz in all single cycle instructions except the branch instruction
- ◆ Addressing modes include direct, indirect and relative addressing modes
- ◆ Power-on Reset
- ◆ Power edge-detector Reset
- ◆ Sleep Mode for power saving
- ◆ 8-bit real time clock/counter(RTCC) with 8-bit programmable prescaler
- ◆ 4 types of oscillator can be selected by programming option:
  - RC - Low cost RC oscillator
  - LFXT - Low frequency crystal oscillator
  - XTAL - Standard crystal oscillator
  - HFXT - High frequency crystal oscillator
- ◆ 4 oscillator start-up time can be selected by programming option:
  - 150  $\mu$ s, 20 ms, 40 ms, 80 ms
- ◆ On-chip RC oscillator based Watchdog Timer(WDT) can be operated freely
- ◆ Pull up resistors for the following pins :
  - PA0~PA3, PB0~PB7, /MCLR, RTCC

- ◆ Pull down resistors for the following pins :  
PA0~PA3, PB0~PB7, RTCC
- ◆ 12 I/O pins with their own independent direction control

### **3. Applications**

The application areas of this MDT1010 range from appliance motor control and high speed automotive to low power remote transmitters/receivers, pointing devices, and telecommunications processors, such as Remote controller, small instruments, chargers, toy, automobile and PC peripheral ... etc.

### **4. Pin Assignment**

PA2	1	18	PA1
PA3	2	17	PA0
RTCC	3	16	OSC1
/MCLR	4	15	OSC2
V <sub>ss</sub>	5	14	V <sub>dd</sub>
PB0	6	13	PB7
PB1	7	12	PB6
PB2	8	11	PB5
PB3	9	10	PB4

### **5. Pin Function Description**

Pin Name	I/O	Function Description
PA0~PA3	I/O	Port A, TTL input level
PB0~PB7	I/O	Port B, TTL input level
RTCC	I	Real Time Clock/Counter, Schmitt Trigger input levels
/MCLR	I	Master Clear, Schmitt Trigger input levels
OSC1	I	Oscillator Input
OSC2	O	Oscillator Output
V <sub>dd</sub>		Power supply
V <sub>ss</sub>		Ground

## 6. Memory Map

### (A) Register Map

Address	Description
00	Indirect Addressing Register
01	RTCC
02	PC
03	STATUS
04	MSR
05	Port A
06	Port B
07~1F	Internal RAM, General Purpose Register

(1) IAR ( Indirect Address Register) : R0

(2) RTCC (Real Time Counter/Counter Register) : R1

(3) PC (Program Counter) : R2

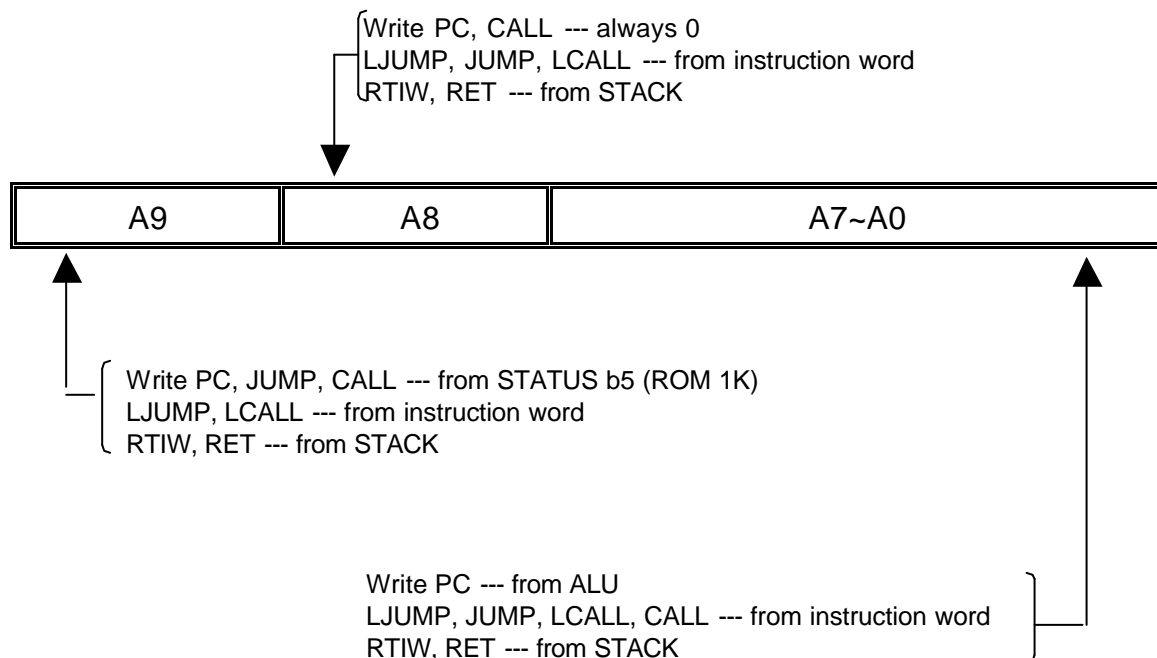

(4) STATUS (Status register) : R3

Bit	Symbol	Function
0	C	Carry bit
1	HC	Half Carry bit
2	Z	Zero bit
3	PF	Power loss Flag bit
4	TF	Time overflow Flag bit
5	page 0	Page select bit : 0 : 000H --- 1FFH 1 : 200H --- 3FFH
6—7	—	General purpose bit

(5) MSR (Memory Select Register) : R4

(6) PORT A : R5

PA3~PA0, I/O Register

(7) PORT B : R6

PB7~PB0, I/O Register

(8) TMR (Time Mode Register)

Bit	Symbol	Function		
		Prescaler Value	RTCC rate	WDT rate
2—0	PS2—0	0 0 0	1 : 2	1 : 1
		0 0 1	1 : 4	1 : 2
		0 1 0	1 : 8	1 : 4
		0 1 1	1 : 16	1 : 8
		1 0 0	1 : 32	1 : 16
		1 0 1	1 : 64	1 : 32
		1 1 0	1 : 128	1 : 64
		1 1 1	1 : 256	1 : 128
3	PSC	Prescaler assignment bit : 0 — RTCC 1 — Watchdog Timer		
4	TCE	RTCC signal Edge : 0 — Increment on low-to-high transition on RTCC pin 1 — Increment on high-to-low transition on RTCC pin		
5	TCS	RTCC signal set : 0 — Internal instruction cycle clock 1 — Transition on RTCC pin		

(9) CPIO A, CPIO B (Control Port I/O Mode Register)

The CPIO register is “write-only”

= “0”, I/O pin in output mode;

= “1”, I/O pin in input mode.

(10) Configuration ROM :

Bit 1	Bit 0	Oscillator Type
0	0	RC Oscillator
0	1	LFXT Oscillator
1	0	XTAL Oscillator
1	1	HFXT Oscillator

Bit 3	Bit 2	Oscillator Start-up Time
0	0	150 $\mu$ s
0	1	20 ms
1	0	40 ms
1	1	80 ms

Bit 4	Watchdog Timer control
0	Watchdog timer disable all the time
1	Watchdog timer enable all the time

Bit 5	Power Edge-detector
0	Disable
1	Enable

(B) Program Memory

Address	Description
000-3FF	Program memory
3FF	The starting address of the power on, external reset or WDT

## 7. Reset Condition for all Registers

Register	Address	Power-On Reset	/MCLR or WDT Reset
IAR	00h	-	-
RTCC	01h	xxxx xxxx	uuuu uuuu
PC	02h	1111 1111	1111 1111
STATUS	03h	0001 1xxx	000# #uuu
MSR	04h	111x xxxx	111u uuuu
PORT A	05h	---- xxxx	---- uuuu
PORT B	06h	xxxx xxxx	uuuu uuuu

Note : u = unchanged, x = unknown, - = unimplemented, read as "0"  
# = value depends on the condition of the following table

Condition	Status: bit 4	Status: bit 3
/MCLR reset (not during SLEEP)	u	u
/MCLR reset during SLEEP	1	0
WDT reset (not during SLEEP)	0	1
WDT reset during SLEEP	0	0

## 8. Instruction Set

Instruction Code	Mnemonic Operands	Function	Operating	Status
010000 00000000	NOP	No operation	None	
010000 00000001	CLRWT	Clear Watchdog timer	0 WT	TF, PF
010000 00000010	SLEEP	Sleep mode	0 WT stop OSC	TF, PF
010000 00000011	TMODE	Load W to TMODE register	W TMODE	None
010000 00000100	RET	Return	Stack PC	None
010000 00000rrr	CPIO R	Control I/O port register	W CPIO r	None
010001 1rrrrrrr	STWR R	Store W to register	W R	None
011000 trrrrrrr	LDR R, t	Load register	R t	Z
111010 iiiiii	LDWI I	Load immediate to W	I W	None
010111 trrrrrrr	SWAPR R, t	Swap halves register	[R(0~3) ↔ R(4~7)] t	None
011001 trrrrrrr	INCR R, t	Increment register	R + 1 t	Z
011010 trrrrrrr	INCRSZ R, t	Increment register, skip if zero	R + 1 t	None

Instruction Code	Mnemonic Operands	Function	Operating	Status
011011 trrrrrrr	ADDWR R, t	Add W and register	W + R t	C, HC, Z
011100 trrrrrrr	SUBWR R, t	Subtract W from register	R - W t (R+/W+1 t)	C, HC, Z
011101 trrrrrrr	DECR R, t	Decrement register	R - 1 t	Z
011110 trrrrrrr	DECRSZ R, t	Decrement register, skip if zero	R - 1 t	None
010010 trrrrrrr	ANDWR R, t	AND W and register	R W t	Z
110100 iiiiii	ANDWI i	AND W and immediate	i W W	Z
010011 trrrrrrr	IORWR R, t	Inclu. OR W and register	R W t	Z
110101 iiiiii	IORWI i	Inclu. OR W and immediate	i W W	Z
010100 trrrrrrr	XORWR R, t	Exclu. OR W and register	R W t	Z
110110 iiiiii	XORWI i	Exclu. OR W and immediate	i W W	Z
011111 trrrrrrr	COMR R, t	Complement register	/R t	Z
010110 trrrrrrr	RRR R, t	Rotate right register	R(n) R(n-1), C R(7), R(0) C	C
010101 trrrrrrr	RLR R, t	Rotate left register	R(n) r(n+1), C R(0), R(7) C	C
010000 1xxxxxxx	CLRW	Clear working register	0 W	Z
010001 0rrrrrrr	CLRR R	Clear register	0 R	Z
0000bb brrrrrrr	BCR R, b	Bit clear	0 R(b)	None
0010bb brrrrrrr	BSR R, b	Bit set	1 R(b)	None
0001bb brrrrrrr	BTSC R, b	Bit Test, skip if clear	Skip if R(b)=0	None
0011bb brrrrrrr	BTSS R, b	Bit Test, skip if set	Skip if R(b)=1	None
1000nn nnnnnnnn	LCALL n	Long CALL subroutine	n PC, PC+1 Stack	None
1010nn nnnnnnnn	LJUMP n	Long JUMP to address	n PC	None
110000 nnnnnnnn	CALL n	Call subroutine	n PC, PC+1 Stack	None
110001 iiiiii	RTIW i	Return, place immediate to W	Stack PC, i W	None
11001n nnnnnnnn	JUMP n	JUMP to address	n PC	None

## Note :

W	:	Working register	b	:	Bit position
WT	:	Watchdog timer	t	:	Target
TMODE	:	TMODE mode register	0	:	Working register
CPIO	:	Control I/O port register	1	:	General register

TF	: Timer overflow flag	R	: General register address
PF	: Power loss flag	C	: Carry flag
PC	: Program Counter	HC	: Half carry
OSC	: Oscillator	Z	: Zero flag
Inclu.	: Inclusive ‘ ’	/	: Complement
Exclu.	: Exclusive ‘ ’	x	: Don’ t care
AND	: Logic AND ‘ ’	i	: Immediate data ( 8 bits )
		n	: Immediate address

## 9. Electrical Characteristics

### (A) Operating Voltage & Frequency

$V_{dd}$  : 2.3 V ~ 6.3 V

Frequency : 0 Hz ~ 20 MHz

### (B) Input Voltage

@  $V_{dd} = 5.0$  V, Temperature = 25

	Port	Min.	Max.
$V_{il}$	PA, PB	$V_{ss}$	1.0 V
	RTCC, /MCLR	$V_{ss}$	0.8 V
$V_{ih}$	PA, PB	2.0 V	$V_{dd}$
	RTCC, /MCLR	3.5 V	$V_{dd}$

#### \* **Threshold Voltage :**

Port A, Port B  $V_{th} = 1.54$  V

RTCC, /MCLR  $V_{il} = 1.35$  V,  $V_{ih} = 2.85$  V (Schmitt Trigger)

(C) Output Voltage :

@  $V_{dd} = 5.0\text{ V}$ , Temperature = 25 , the typical value as followings :

PA, PB Port	
$I_{oh} = -20.0\text{ mA}$	$V_{oh} = 3.50\text{ V}$
$I_{ol} = 20.0\text{ mA}$	$V_{ol} = 0.60\text{ V}$
$I_{oh} = -5.0\text{ mA}$	$V_{oh} = 4.60\text{ V}$
$I_{ol} = 5.0\text{ mA}$	$V_{ol} = 0.25\text{ V}$

(D) Leakage Current

@  $V_{dd} = 5.0\text{ V}$ , Temperature = 25 , the typical value as followings :

$I_{il}$	- 1.0 $\mu\text{A}$ (Max.)
$I_{ih}$	+ 1.0 $\mu\text{A}$ (Max.)

(E) Sleep Current

@**WDT - Disable**, Temperature = 25 , the typical value as followings :

$$V_{dd} = 2.3\text{ V} \sim 6.3\text{V} \quad I_{dd} < 1.0\mu\text{A}$$

@**WDT - Enable**, Temperature = 25 , the typical value as followings :

$V_{dd} = 2.3\text{ V}$	$I_{dd} < 1.0\ \mu\text{A}$
$V_{dd} = 3.0\text{ V}$	$I_{dd} = 1.2\ \mu\text{A}$
$V_{dd} = 4.0\text{ V}$	$I_{dd} = 4.0\ \mu\text{A}$
$V_{dd} = 5.0\text{ V}$	$I_{dd} = 12.0\ \mu\text{A}$
$V_{dd} = 6.3\text{ V}$	$I_{dd} = 20.0\ \mu\text{A}$

(F) Operation Current

Temperature = 25 , the typical value as followings :

(i) OSC Type = RC ; WDT - Enable; @  $V_{dd} = 5.0\text{ V}$

Cext. (F)	Rext. (Ohm)	Frequency (Hz)	Current (A)
3P	4.7 K	10.26 M	1.35 m
	10.0 K	6.00 M	790.0 μ
	47.0 K	1.476 M	230.0 μ
	100.0 K	724.4 K	135.0 μ
	300.0 K	242.4 K	70.0 μ
	470.0 K	151.6 K	60.0 μ
20P	4.7 K	5.12 M	680.0 μ
	10.0 K	2.774 M	390.0 μ
	47.0 K	640.0 K	125.0 μ
	100.0 K	307.6 K	78.0 μ
	300.0 K	101.2K	55.0 μ
	470.0 K	63.68 K	50.0 μ
100P	4.7 K	1.53 M	240.0 μ
	10.0 K	781.2 K	140.0 μ
	47.0 K	172.4.0K	65.0 μ
	100.0 K	82.0 K	50.0 μ
	300.0 K	27.0 K	47.0 μ
	470.0 K	17.0 K	45.0 μ
300P	4.7 K	633.6 K	125.0 μ
	10.0 K	322.4 K	85.0 μ
	47.0 K	69.60 K	55.0 μ
	100.0 K	33.04 K	50.0 μ
	300.0 K	10.8 K	45.0 μ
	470.0 K	6.84 K	43.0 μ

(ii) OSC Type = LF (C=20 p); WDT - Disable; PED-Disable

Voltage/Frequency	32 K	455 K	1 M	Sleep
2.3 V	4.0 μA	X	X	< 1.0 μA
3.0 V	6.0 μA	50.0 μA	80.0 μA	< 1.0 μA
4.0 V	15.0 μA	70.0 μA	125.0 μA	< 1.0 μA
5.0 V	30.0 μA	120.0 μA	200.0 μA	< 1.0 μA
6.3 V	40.0 μA	180.0 μA	250.0 μA	< 1.0 μA

(iii) OSC Type = XT (C=10 p); WDT - Enable; PED-Disable

Voltage/Frequency	1 M	4 M	10 M	Sleep
2.1 V	65.0 $\mu$ A	210.0 $\mu$ A	480.0 $\mu$ A	< 1.0 $\mu$ A
3.0 V	130.0 $\mu$ A	360.0 $\mu$ A	760.0 $\mu$ A	1.2 $\mu$ A
4.0 V	220.0 $\mu$ A	620.0 $\mu$ A	1.25 mA	4.0 $\mu$ A
5.0 V	330.0 $\mu$ A	980.0 $\mu$ A	1.80 mA	12.0 $\mu$ A
6.3 V	530.0 $\mu$ A	1.7 mA	2.70 mA	20.0 $\mu$ A

(iv) OSC Type = HF (C=10 p); WDT - Enable; PED-Disable

Voltage/Frequency	4 M	10 M	20 M	Sleep
2.1 V	190.0 $\mu$ A	420.0 $\mu$ A	@2.3v900.0 $\mu$ A	< 0.1 $\mu$ A
3.0 V	350.0 $\mu$ A	740.0 $\mu$ A	1.40 mA	1.2 $\mu$ A
4.0 V	670.0 $\mu$ A	1.3 mA	2.2 mA	4.0 $\mu$ A
5.0 V	1.1 mA	2.0 mA	3.2 mA	12.0 $\mu$ A
6.3 V	1.9 mA	3.0 mA	4.7 mA	20.0 $\mu$ A

(G) Pull Resistance

@ Input Mode :  $V_{dd} = 3.0$  V

PORT	Pull-High Resistance	$R_{hi} = 300.0$ KOhm
	Pull-Low Resistance	$R_{lo} = 300.0$ KOhm
RTCC	Pull-High Resistance	$R_{hi} = 280.0$ KOhm
	Pull-Low Resistance	$R_{lo} = 280.0$ KOhm
/MCLR	Pull-High Resistance	$R_{hi} = 150.0$ KOhm

@ Input Mode :  $V_{dd} = 5.0$  V

PORT	Pull-High Resistance	$R_{hi} = 100.0$ KOhm
	Pull-Low Resistance	$R_{lo} = 100.0$ KOhm
RTCC	Pull-High Resistance	$R_{hi} = 110.0$ KOhm
	Pull-Low Resistance	$R_{lo} = 110.0$ KOhm
/MCLR	Pull-High Resistance	$R_{hi} = 100.0$ KOhm

***p.s. : It is only a reference value for the Pull High/Low Resistance, and the accurate***

**value of the Resistance depends on the various parameter of the Process. But the variation of the value will be not more than 20%.**

(H) Power Edge-detector Reset Voltage (Not in Sleep Mode), @  $V_{dd} = 5.0\text{ V}$

$V_{pr} = 1.1\sim 1.3\text{ V}$        $V_{pr} : V_{dd}$  (Power Supply)

(I) The basic WDT time-out cycle time

Temperature = 25 °C, the typical value as followings :

Voltage (V)	Basic WDT time-out cycle time (ms)
2.3	34.00
3.0	27.60
4.0	23.20
5.0	20.40
6.3	18.00

(J) MCLRB Filter : @  $V_{dd}=5.0\text{v}$

$W_m \geq 1.2\mu\text{s}$        $W_m$  : Filter pulse width (low) in /MCLR pin.

10. Port A and Port B Equivalent Circuit

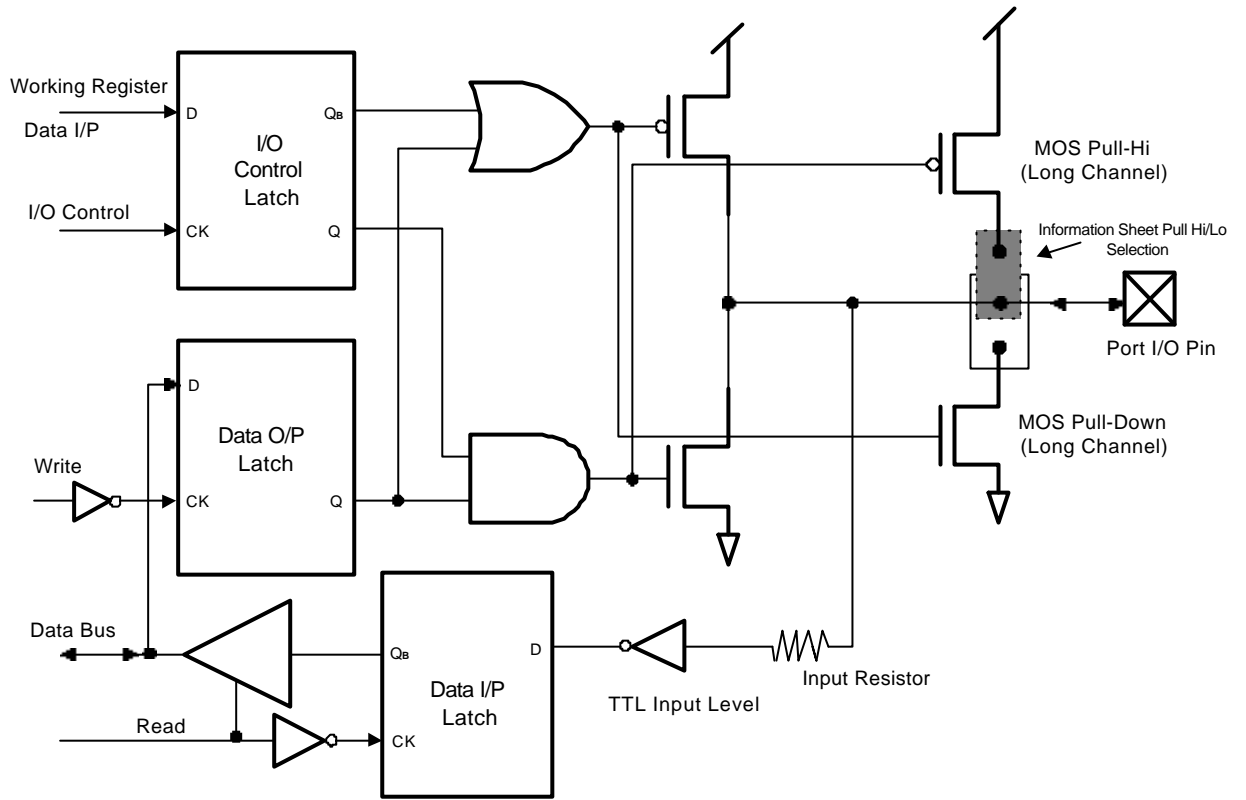

11. MCLRB and RTCC Input Equivalent Circuit

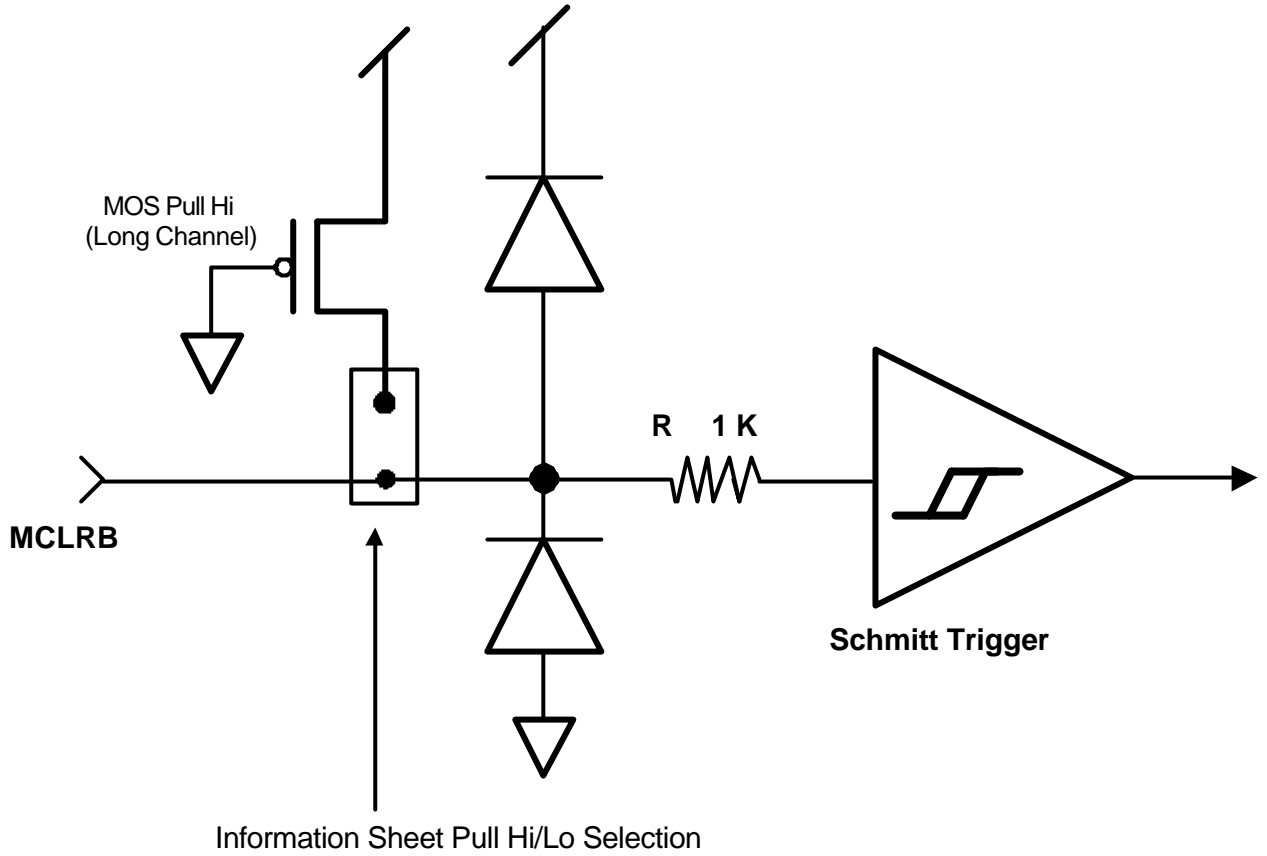

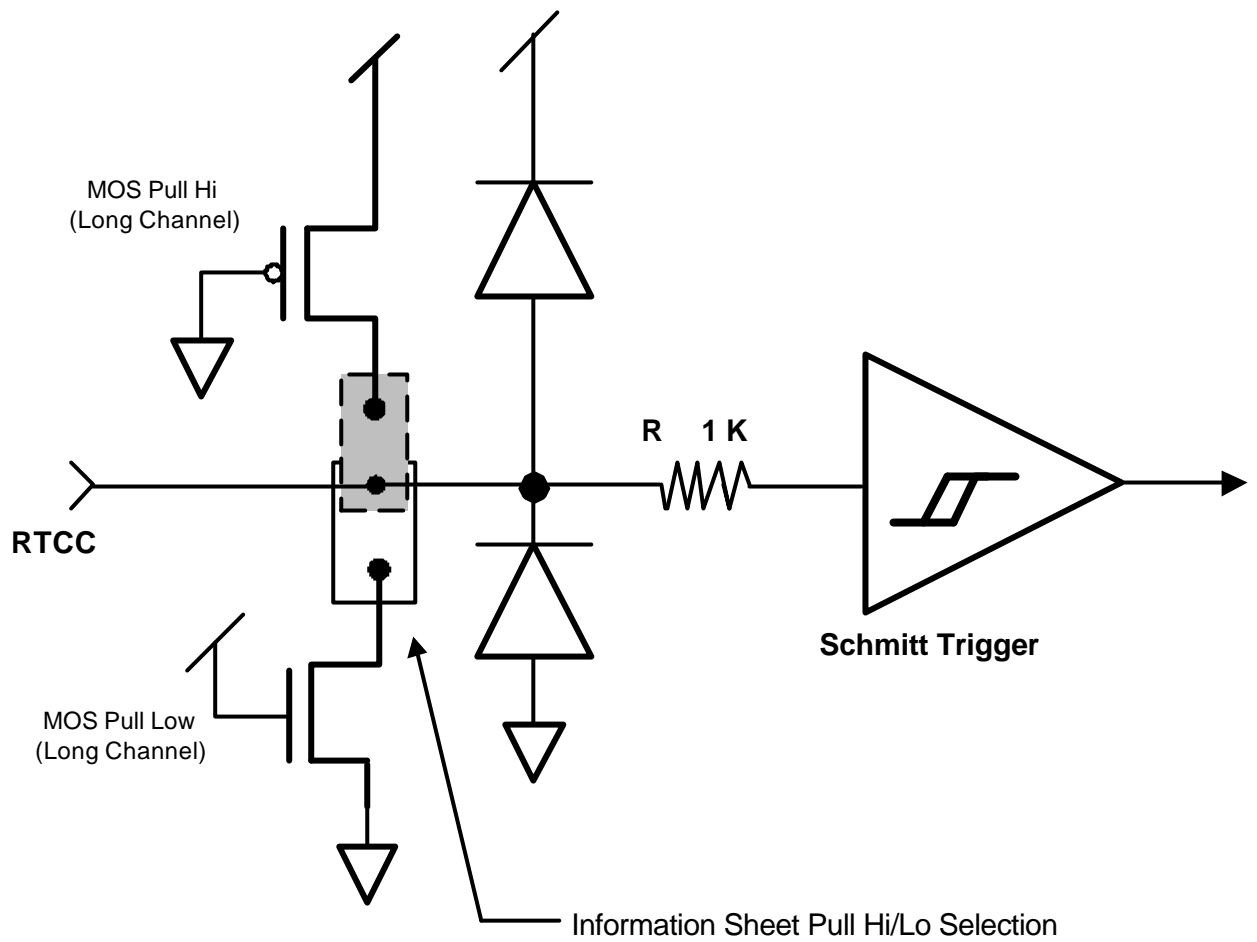

## 12. Block Diagram

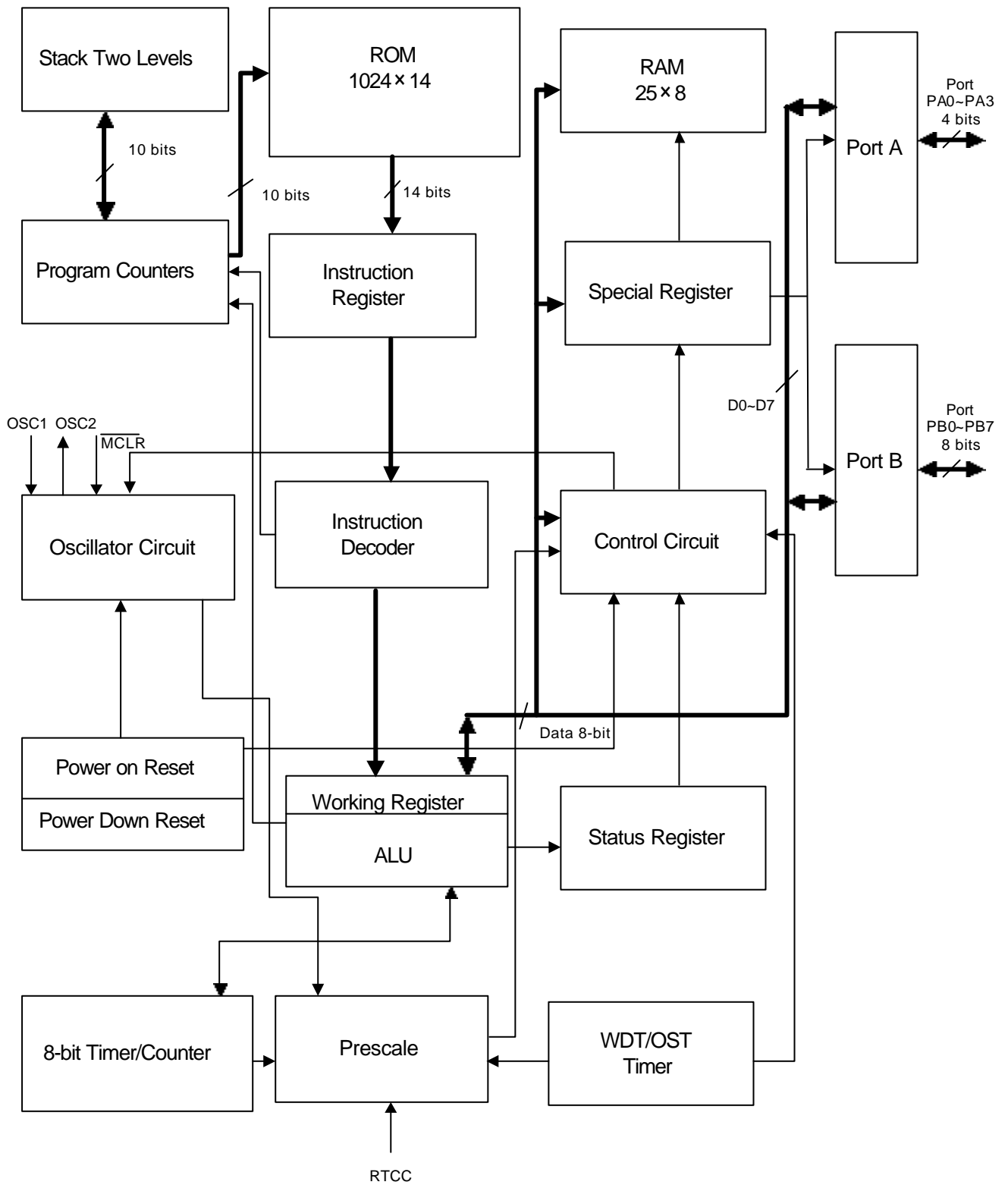

*This specification are subject to be changed without notice. Any latest information please preview*

### 13. External Capacitor Selection For Crystal Oscillator

@  $V_{dd} = 5.0\text{ V}$

Osc. Type	Resonator Freq.	Capacitor Range
HF	20 MHz	20 pF ~30 pF
	10 MHz	3 pF ~10 pF
	4 MHz	3 pF ~10 pF
XT	10 MHz	3 pF ~10 pF
	4 MHz	3 pF ~10 pF
	1 MHz	10 pF ~30 pF
LF	1 MHz	3 pF ~10 pF
	455 K	30 pF ~100 pF
	32 K	20 pF ~50 pF

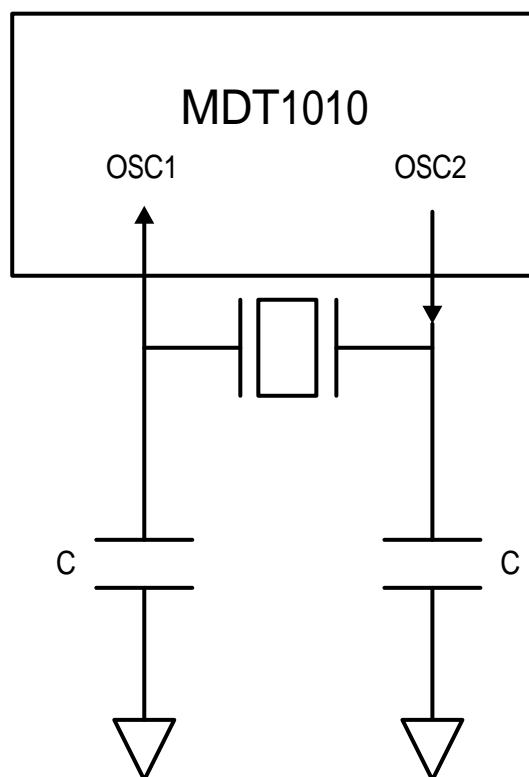

To increase the stability of oscillator and the ability of anti-noise, the above values of the external capacitor range can be recommended for reference, but the higher capacitance also increases the start-up time.

*This specification are subject to be changed without notice. Any latest information please preview*